



# TKE 944

## Machining Centres



Mobile gantry 4-axis CNC machining centre for drilling, milling and tapping, at any angle from  $-90^{\circ}$  to  $+90^{\circ}$ , on profiles and plates with a thickness up to 10 mm if made of aluminium, lightweight alloys and PVC and up to 2 mm if made of steel. The moving part of the machine consists of a gantry with precision rack and pinion drive. The 8,5 kW electrically-driven spindle with ISO 30 tool holder allows machining operations, including heavy-duty work, with optimum results in terms of speed and accuracy. The machine can be used in double mode (7000 model) so as to minimize machine downtime, as it is possible to change the workpiece (load/ unload) and the automatic setting of the vices in "concealed" time. It is also possible to load and consequently machine different workpieces between the two work areas. The automatic tool magazine for 4.000 mm version is available in a fixed solution on board the machine with 4/8 places, recommended for single place machining. Otherwise a 12-place automatic magazine on board the carriage, ideal to allow a faster tool change and useful for the double mode machining, is available. The 7.000 version is supplied with the 12-place automatic magazine on board the carriage. The gantry is provided with a guard which, besides protecting the operator, also reduces the noise impact on the environment.

**Emmegi S.p.A.**  
Via delle Industrie, 2  
20044 - Arese (MI)  
ITALY

Tel 39 02356961  
P.IVA 01978870366  
info@tekna.it  
www.tekna.it

The right to make technical alterations is reserved.

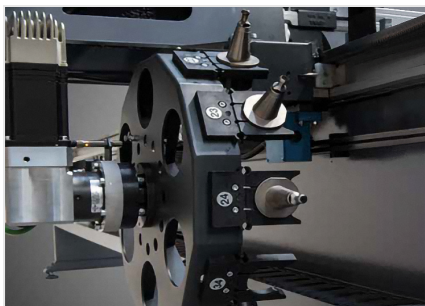

**12-place tool magazine**

The machine can be equipped with a 12-place automatic magazine installed on board the carriage moving on the X-axis. This configuration replaces or supplements the 4/8-place fixed magazines on the left-hand side of the machine. This solution, required to perform machining in double operation mode, considerably reduces the tool change times and consequently increases the machine productivity and efficiency.

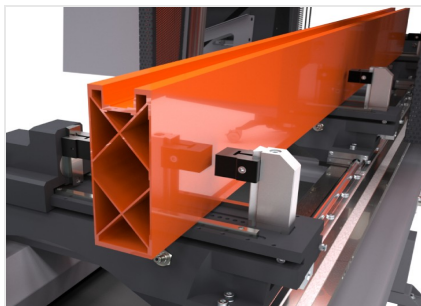

**Vices**

The vice unit can ensure the correct and safe clamping of large aluminium, steel and light alloy profiles. The vice size and the long Y stroke of the electrospindle allow machining large profiles for all kinds of civil and industrial applications. Each unit slides on special linear guides on machine surface. The positioning is managed by the X axis.

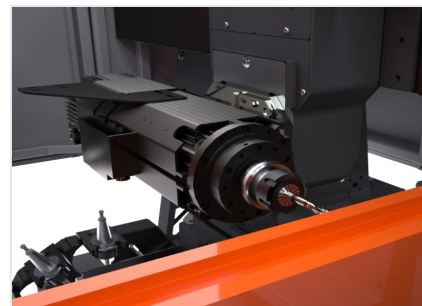

**Electric head**

8.5 kW S1 high torque electrospindle allows heavy duty machining. The electrospindle movement along C axis allows performing rotations from -90° to +90° and working on 3 sides of the profile with no need to reposition it. It can be used both with some types of extruded steel and with aluminium profiles, thanks to the lubrication system with oil emulsion spray mist or, as an option, with minimal diffusion oil.

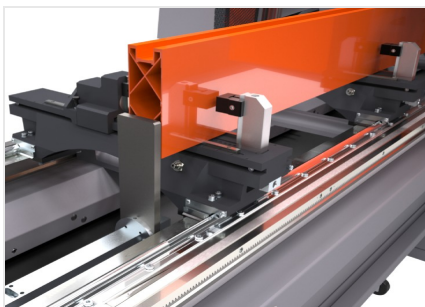

**Profile positioning**

The machine is equipped with two sturdy and precise pneumatic reference stops, used to machine one or two profiles in multi-piece or double operation mode (model 7,000 only). A laser system is available for accurately positioning the workpieces on the work surface; it reads each profile and sets the reference without the need for mechanical stops.

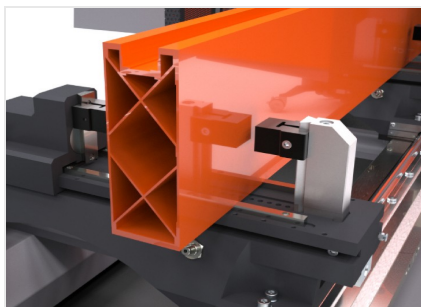

**Additional vices (Optional)**

If necessary, it is possible to install additional vices beyond the standard machine equipment. In this way, it is possible to ensure perfect clamping of bars or bar sections even in complex cases in terms of number, size or types of profiles to be machined. Moreover, the additional vices allow greater versatility in vice position depending on the length of the workpieces and the machining to be performed.



**Dimensional profile measurer (Optional)**

The machine can be optionally equipped with an electronic device that automatically corrects workpiece dimensional errors in length, width and height. In this way, the accuracy of the machine is not influenced by the differences between theoretic and actual workpiece dimensions during machining.





**TKE 944 / MACHINING CENTRES**

**LAYOUT**

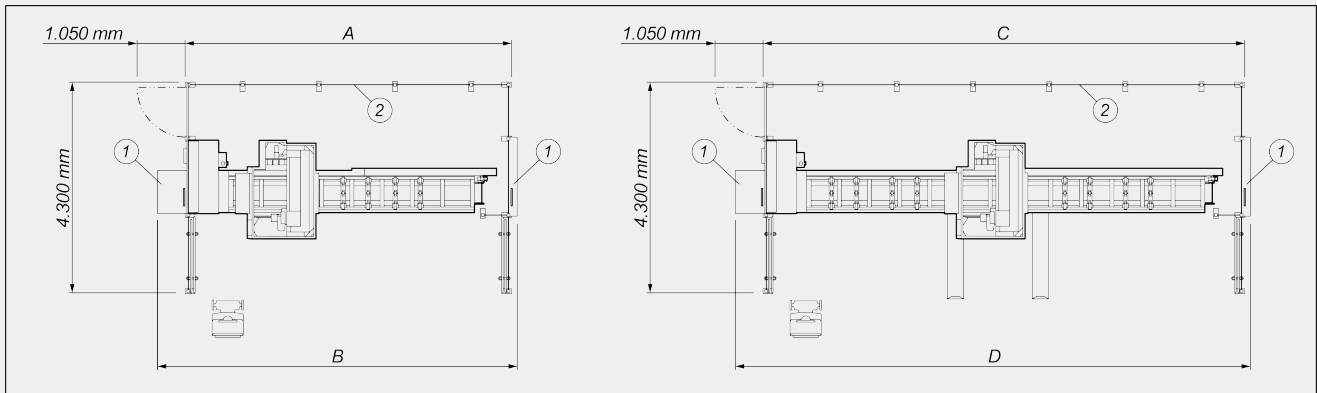

	<b>A</b>	<b>B</b>	<b>C</b>	<b>D</b>
<b>TKE 944 - 4m (mm)</b>	6.700	7.400	-	-
<b>TKE 944 - 7m (mm)</b>	-	-	9.800	10.500

1. Provision of the machine for extended machining management (optional)
2. Enclosure guard of the 4th side (optional)

The overall dimensions may vary depending on the product configuration.

**AXIS STROKES**

X AXIS (longitudinal) (mm)	4.000 ; 7.000
Y AXIS (transversal) (mm)	1.070
Z AXIS (vertical) (mm)	550
C AXIS (vertical-horizontal rotation of the head)	-90° ÷ +90°

**ELECTROSPINDLE**

Maximum speed (rpm)	24.000
Maximum power in S1 (kW)	8,5
Maximum torque (Nm)	13,5



**AUTOMATIC TOOL MAGAZINES (4,000 Version)**

Number of angle machining heads which can be loaded onto the automatic magazine	2
Automatic 12-place tool magazine on board the gantry (**)	<input type="radio"/>
Maximum size of tools which can be loaded onto the revolver magazine (mm)	Ø = 180 - L = 200
Fixed left 4-place tool magazine	<input type="radio"/>
Fixed left 8-place tool magazine	<input type="radio"/>
Maximum size of tools which can be loaded onto the 4/8-place magazine (mm)	Ø = 120 - L = 180
Fixed left 7-place tool magazine	<input type="radio"/>
Number of angle machining heads which can be loaded onto the 7-place magazine	2
Maximum size of tools which can be loaded onto the 7-place magazine (mm)	Ø = 180 - L = 200

(\*\*) if the provision for angle head is configured, the places in the magazine are reduced to 10

**AUTOMATIC TOOL MAGAZINE (7,000 Version)**

Automatic 12-place tool magazine on board the gantry (**)	<input checked="" type="radio"/>
Number of angle machining heads which can be loaded onto the automatic magazine	2
Maximum size of tools which can be loaded onto the revolver magazine (mm)	Ø = 180 - L = 200

(\*\*) if the provision for angle head is configured, the places in the magazine are reduced to 10



**WORKABLE SIDES**

With direct tool (upper face, side faces)	3
With angular head (top face, side faces, ends)	1 + 2 + 2

**WORK AREA**

**1F = 1 face machining**

**5F = 5 faces machining**

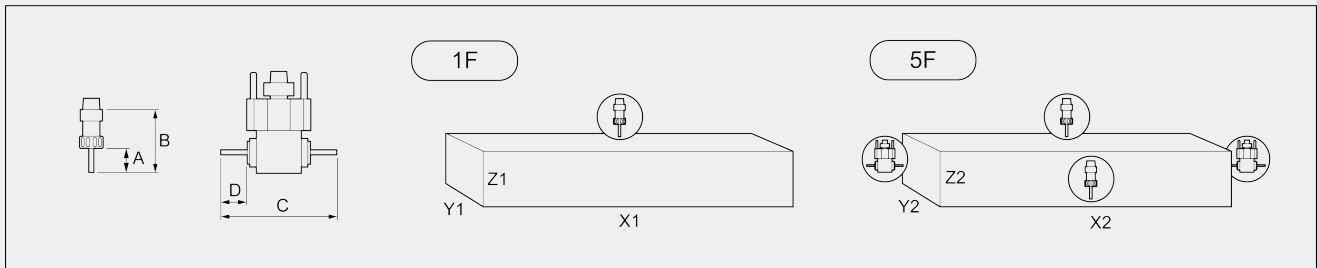

**Configurations with 12-place automatic tool magazine on board the carriage**

		A	B	C	D	X1	Y1 (a)	Z1	X2	Y2 (b)	Z2
<b>TKE 944-4</b>	single mode	60	107	255	55	3.940	450	250	3.800	410	250
<b>TKE 944-7</b>	single mode	60	107	255	55	7.000	450	250	6.850	410	250
	double mode	60	107	255	55	2.800	450	250	2.650	410	250

**Configuration with one 4-place fixed tool magazine**

		A	B	C	D	X1	Y1 (a)	Z1	X2	Y2	Z2
<b>TKE 944-4</b>	single mode	60	107	255	55	3.850	450	250	-	-	-

**Configuration with one 8-place fixed tool magazine**

		A	B	C	D	X1	Y1 (a)	Z1	X2	Y2	Z2
<b>TKE 944-4</b>	single mode	60	107	255	55	3.850	450	250	-	-	-

**Configuration with 7-place fixed tool magazine**

		A	B	C	D	X1	Y1 (a)	Z1	X2	Y2 (b)	Z2
<b>TKE 944-4</b>	single mode	60	107	255	55	3.850	450	250	3.250	410	250

Dimensions in mm

(a) size clampable with vice without standard end pieces

(b) size clampable with vice with one 40 mm standard end piece at operator side



**TAPPING CAPACITY (with Tap On Aluminium And Through Hole)**

With compensator

M8





**PROFILE POSITIONING**

Maximum number of reference pneumatic stops	2
Workpiece reference pneumatic side stops (4,000- 7,000)	1 - 2
Additional pneumatic side stop with separate vice control system (version 4,000)	<input type="radio"/>

**WORKPIECE LOCKING**

Standard number of pneumatic vices (4,000 - 7,000)	4 - 8
Maximum number of pneumatic vices (4,000 - 7,000)	12 - 16
Automatic vice positioning through X axis	<input checked="" type="radio"/>
Double horizontal hold-down devices on pneumatic vices for the machining of two parallel profiles	<input type="radio"/>

Included ● Available ○