

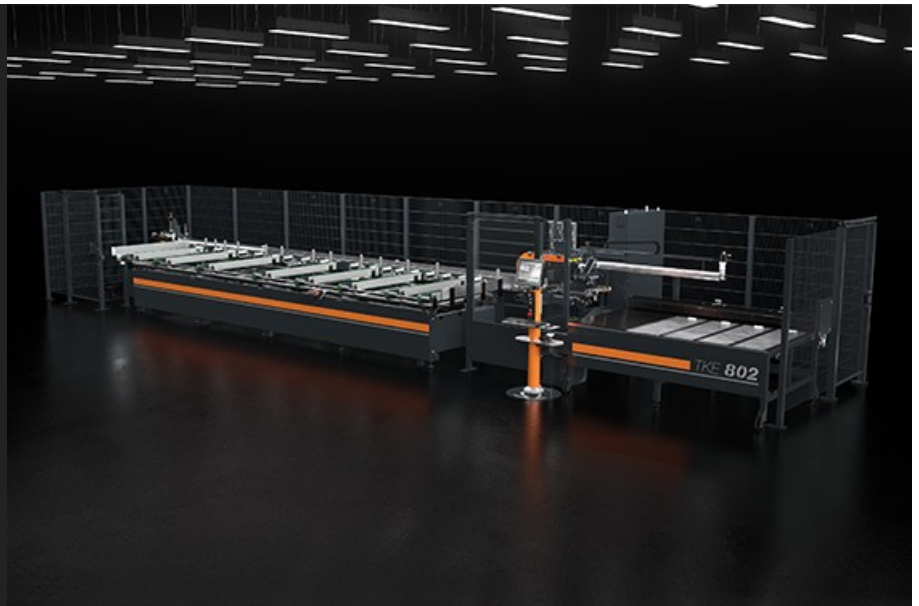

## **TKE 802**

### Cutting Centres



Automatic CNC cutting-off centre with horizontal blade feed, 3 controlled axes, designed for cutting profiles made of aluminium, PVC, light alloys in general. It performs automatic cutting according to predefined and optimized cutting lists. It can perform the bevelled cut on both sides of the profile. The machine is intended to perform cutting at an angle from 45° to 135° or from 22°30' to 157°30'. Automatic bar feeder and automatic unloading magazine on the opposite side. It can be fitted with customised horizontal and vertical drilling units for specific automatic machining operations.



**Bar feeder**

The extremely fast and precise numerical control system (CNC) for bar positioning includes a gripper for clamping the profile and the possibility to manually adjust the position. The movement is transmitted on a rack through a low backlash gearbox to maintain the high standards of precision guaranteed by the CNC. The feeder slides on case-hardened and tempered bars through linear bushings.

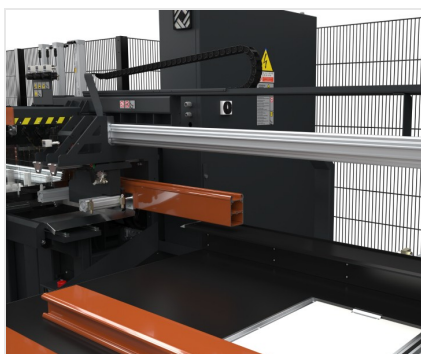

**Ejector**

The ejector controlled by the CNC grips the workpiece during machining and, once completed, shifts it from the cutting area to the unloading magazine, holding it in the same position so as to facilitate the subsequent machining phases. Motion is transmitted by means of a toothed belt and secure gripping of the workpiece is ensured by pneumatic cylinders.



**Control**

The operator interface with 15" touchscreen display has a network connection, USB ports and a floppy disk drive for communicating with external devices. It also features a built-in control panel, mouse and keyboard, it is preset for the installation of a label printer and connection to a remote control panel.



**Loading magazine**

The machine can feature a back-step or belt loading magazine with automatic bar positioning, which can house profiles having a maximum length of 7.5 metres. The back-step magazine is especially suitable for loading profiles having a section which makes it difficult to keep a stable position during transport. In case of stable profiles, the belt loading magazine allows maximum flexibility and capacity.

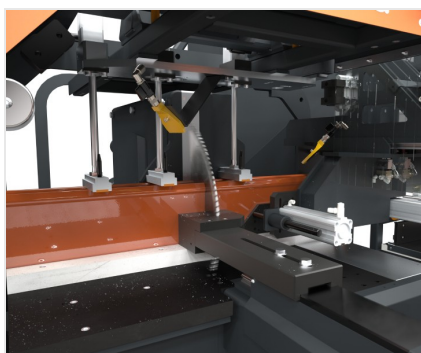

**Cutting module**

The cutting module consists of a single-head cutting off machine with hydro-pneumatic blade feed. It is provided with a 550 mm blade featuring wide cutting range: from 45° to 135° (from 22°30' to 157°30' optional). Setting of the cutting angles is fully automatic and is handled by the CNC.



**Unloading magazine**

The workpiece unloading magazine has an automatic tilting and moving system that enables machining to be performed continuously, thus reducing the cycle time. In addition, the magazine allows finished workpieces to be stacked while a sensor, which emits a signal when the magazine is full, supervises system operation.





### **Label printer (Optional)**

The industrial label printer allows each cut profile to be identified with identifying features from the cutting list. In addition, barcode printing enables easy identification of the profile itself, which is particularly useful for subsequent machining steps on Machining Centres or assisted assembly lines.





**TKE 802 / CUTTING CENTRES**

**LAYOUT**

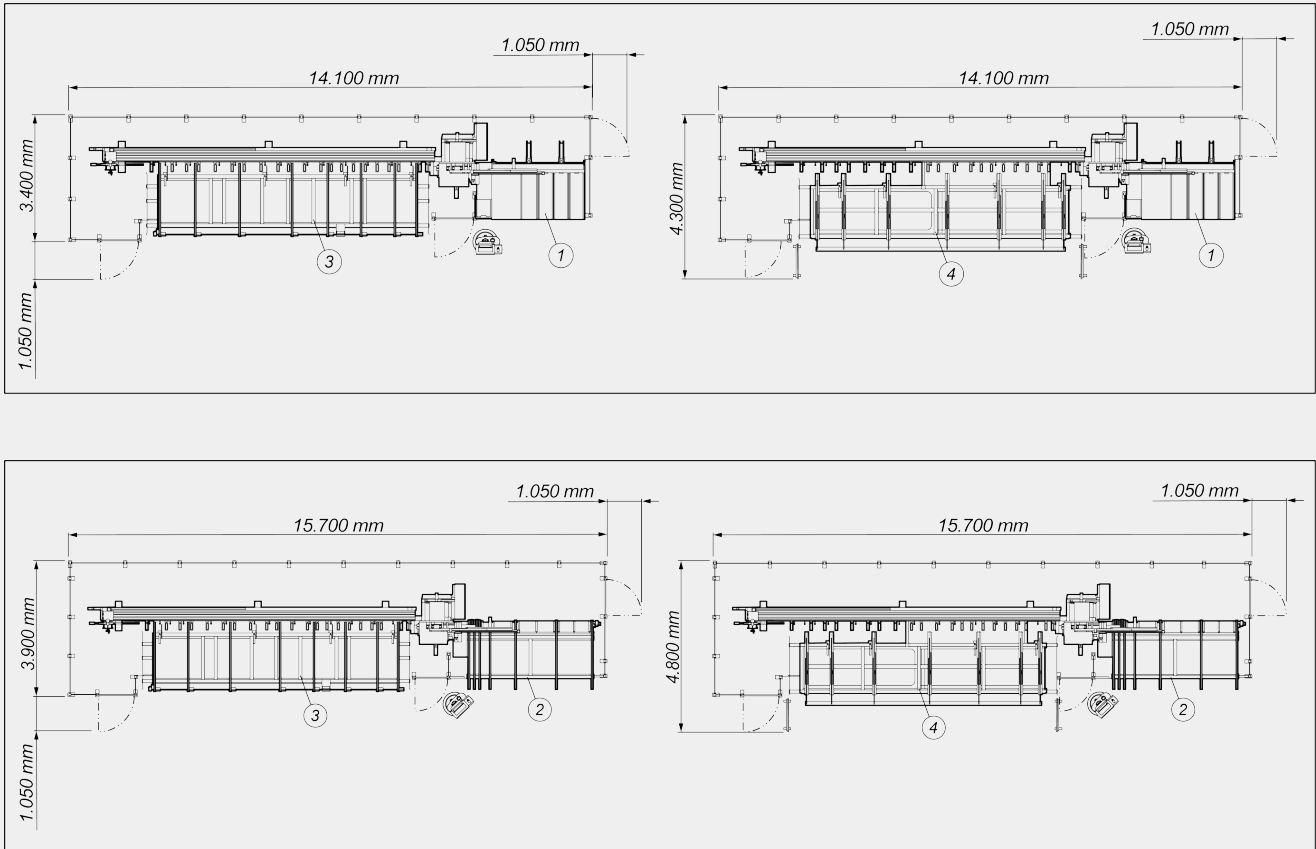

- 1. Unloading magazine with automatic extraction system (standard)
- 2. Belt unloading magazine with automatic extraction system (optional)
- 3. Belt loading magazine (standard)
- 4. Back-step magazine (standard)

The overall dimensions may vary depending on the product configuration.

**AXIS STROKES**

U AXIS (feeder) (mm)	7.500
X AXIS (extractor) (mm)	1.000
B AXIS (angle of blade) (according to version)	45° ÷ 135°; 22°30' ÷ 157°30'



**LOADING UNIT: PROFILE POSITIONING**

Loading feeder up to 7,500 mm with adjustable gripper	●
Belt loading magazine or back-step magazine	●
Theoretical minimum cutting length (mm)	0
Minimum machinable profile section (mm)	30 x 30
Workpiece tilting device to 90° during loading	○

**CUTTING UNIT**

Widia blade (mm)	Ø = 550
Pre-set for swarf exhauster	●
Power rating (kW), "three-phase" blade drive motor	3
Minimal oil diffusion lubrication system	●
Hydro-pneumatic blade feed	●

**CUTTING DIAGRAM**

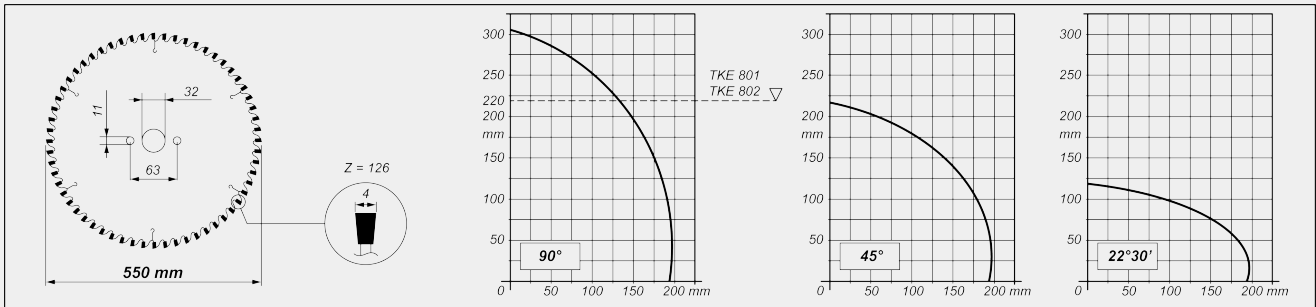

**CUTTING UNIT TILTING**

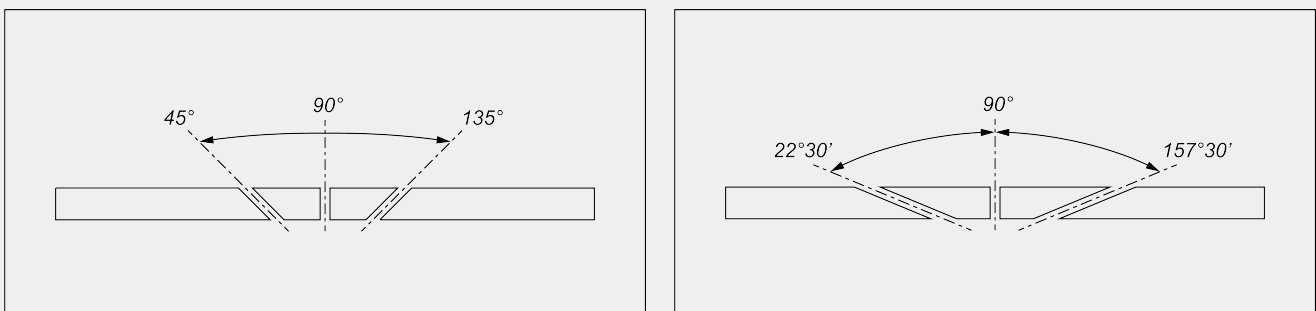

Electronic adjustment of intermediate angles



**UNLOADING UNIT:**

Unloading workbench with automatic extraction system	●
Max. profile length that can be unloaded automatically on standard unloading bench (mm)	2.500

**SAFETY DEVICES AND PROTECTIONS**

Pneumatically-controlled integral guard for cutting area	●
--	---

**WORKPIECE LOCKING**

Vertical pneumatic vices	3
Vice pressure reduction with pressure gauge	●
Horizontal pneumatic vice	●

Included ● Available ○