



# Ba 411

## Manual Assembly Benches



Assembly bench for glazed sashes with work table tilting from 0° (horizontal) to 85°. The drop-away roller conveyor is adjustable in height (from 170 to 460 mm) independently from the work table. The work table is adjustable from 895 to 965 mm while the feet are drilled with holes for floor anchoring. The bench is provided with a central spider clamp for hoisting and positioning the glass.

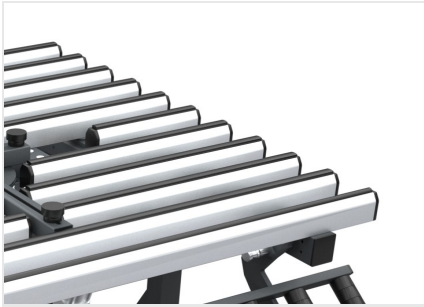

### PVC contact surfaces

The anti-friction hard PVC support surface preserves the integrity of the frame by allowing it to slide.

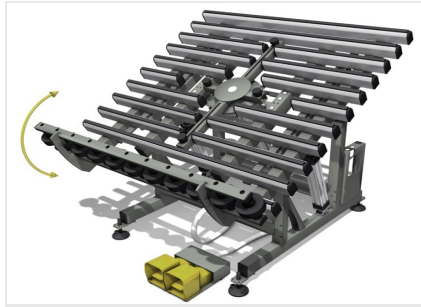

### Tilting work bench

The work bench is tilting with fully pneumatic movement. By means of the footswitch, the work surface can be tilted from 0°, horizontal position, to 85°.



### Pneumatic lifting for glass

The central, retractable crossbeam is equipped with four rubber points for glass support that can be adjusted along the axes. When the bench is in the horizontal position, the crossbeam can be raised by means of the footswitch and rotated manually. A safety system prevents lifting the crossbeam with the bench in a tilted position, or tilting the bench when the crossbeam is raised.

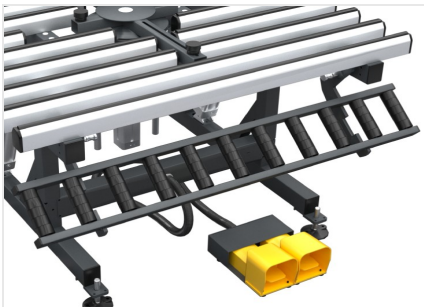

### Door sliding roller conveyor

A manually-operated tilting roller conveyor with automatic locking (to 2 preset positions), allows horizontal translation of the frame, thanks to rollers (mounted on a stem) that ensure high smoothness and ease of movement along the production line.

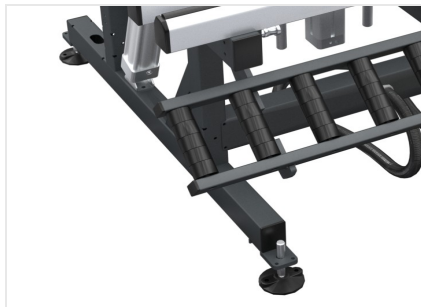

### Adjustable feet

Height-adjustable feet ensure that the desired height for the work bench is achieved and that it is perfectly aligned with the other products in the Dynamic line. The feet also have holes so they can be anchored to the floor.



**BA 411 / MANUAL ASSEMBLY BENCHES****WORK BENCHES**

Hard anti-friction PVC contact surface	●
Pneumatic tilting of work table from 0° (horizontal) to 85°	●

**DIMENSIONS**

Length (mm)	1.400
Width (mm)	1.400
Adjustable work table (horizontal position) (mm)	895 ÷ 965
Raised glass height (mm)	1.200
Weight (kg)	170

**CHARACTERISTICS**

Pneumatic lifting for glass	●
Manually tilting and height-adjustable roller conveyor independently from the work bench	●
Feet with holes for ground fixing	●
Air/cycle absorption (NI)	36
Load capacity (kg)	120
Central lifting device maximum loading capacity (kg)	70

Included ● Available ○