



TKE 151 S

Copy Router



Single-head copy router with manual downfeed. Manually controlled single-head copy router with pneumatic clamping and traverse of the cutting head with indirect lever. Predisposition for performing through machining operations on aluminium without turning the workpiece and for working steel up to 2 mm. Scratch-proof work table. Pneumatic stylus with control on the handle.

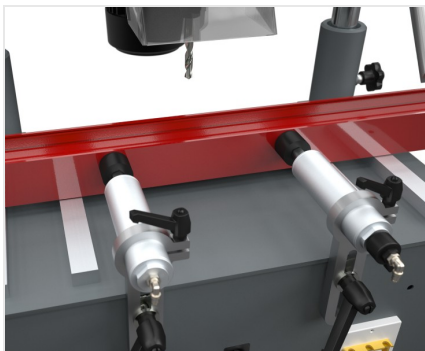

Horizontal vices

The machine is provided with a pair of pneumatic horizontal vices with low pressure device. The vices are adjustable manually and ensure correct gripping of the profile in the machine.



Lubrication

The machine is provided with a spray-mist lubrication system based on water and oil emulsion that ensures correct lubrication of the tool in operation.



Stop adjustment

A stop system with manual adjustment, allows correct positioning of the workpiece in the machine thus bringing it to the cutting area.

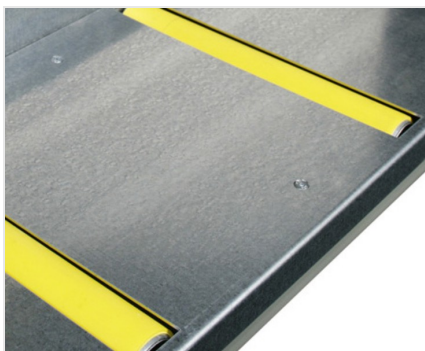

Roller conveyor (Optional)

The machine is designed to accommodate special roller conveyors which can be positioned at the right or left sides, or at both sides. Their function is to support profiles of considerable length and to ensure correct positioning of the workpiece in the machine.

**TKE 151 S / COPY ROUTER****CHARACTERISTICS**

Motor (kW)	0,75
Tool speed (rpm)	10.000
Travel (X-Y-Z) (mm)	314 - 120 - 175
Vice capacity (mm)	175 x 220
Toolholder with gripper max (mm)	Ø = 10
Pair of horizontal pneumatic vices, stroke (mm)	8
6-position positive indexing stop	●
One tooth end-mill (mm)	Ø = 5 - 10
Mill-holder collet complete with lock-nut (mm)	Ø = 10
Three-diameter probe	●
Micro-mist lubrication system with water and oil emulsion	●
Template with standard figures	●
Right and left rods with 4 excludable stops	●

Included ● Available ○