



## *Five CS*

### Manual Assembly Benches



Test bench for frames in aluminium. It allows re-create the conditions of use of the frame. The casement is locked by a system of vices adjustable throughout the casement height; the operator can assemble the sash and the glass inside the casement and finally test it. The roller conveyor allows the operator to feed/outfeed heavy frames in complete autonomy.



**Tilting work bench**

The work bench is tilting with fully pneumatic movement. By means of the footswitch, the work surface can be tilted from 0°, horizontal position, to 85°.



**Support surface in hard anti-friction PVC**

The anti-friction hard PVC support surface ensures great smoothness of the frame allowing easy handling.



**Control and footswitch assembly**

A centre console provides housing for the bi-manual control that manages the locking/unlocking of the frame. In addition, a double footswitch allows the bench to be tipped or the horizontal profile rollers to be operated.



**Door sliding roller conveyor**

A pneumatically-operated tilting roller conveyor allows horizontal translation of the frame by stem-mounted rollers that ensure smoothness and ease of movement.

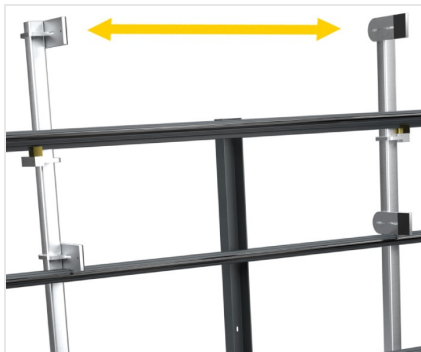

**Frame clamping**

The frame clamping system is self-centring, thanks to a rack that ensures perfect parallelism and uniform pressure through the use of pneumatic cylinders.



**FIVE CS / MANUAL ASSEMBLY BENCHES****CHARACTERISTICS**

Hard anti-friction PVC contact surface	●
Height adjustable work bench (mm)	875 ÷ 925
Tilting work bench from 0° (horizontal) to 85°	●
Adjustable clamping force (max) (N)	660
Vice opening (mm)	425 ÷ 2.425
Vice paddle height (max) (mm)	65
Vice bars with 5 adjustable paddles on both bars (mm)	H = 2.060
Self-centring clamping system with retractable bars	●
Pneumatic tilting of the roller conveyor when the bench is horizontal	●
Loading-unloading infeed roller conveyor with adjustable ground clearance (mm)	305 ÷ 355
Length (mm)	3.000
Air consumption (NI/min)	150
Load capacity (kg)	200
Weight (kg)	330

Included ● Available ○